

# MF515A



## FEATURE

- ✔ Imported motor and high-quality electrical components, pneumatic components.
- ✔ The machine adopts frequency control technology, which can stepless adjust the band feeding speed and glue shaft rotation speed. Thus get the best banding speed for different material and achieve satisfactory processing results.

## PRODUCT HIGHLIGHTS

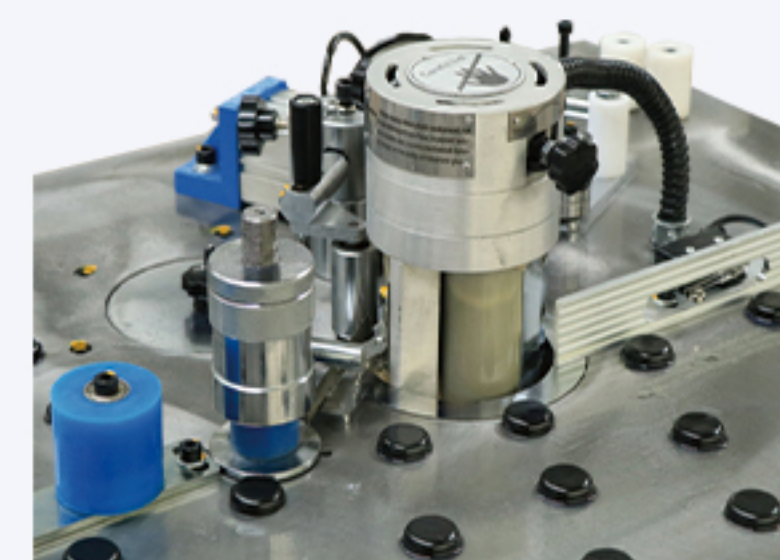

Gluing

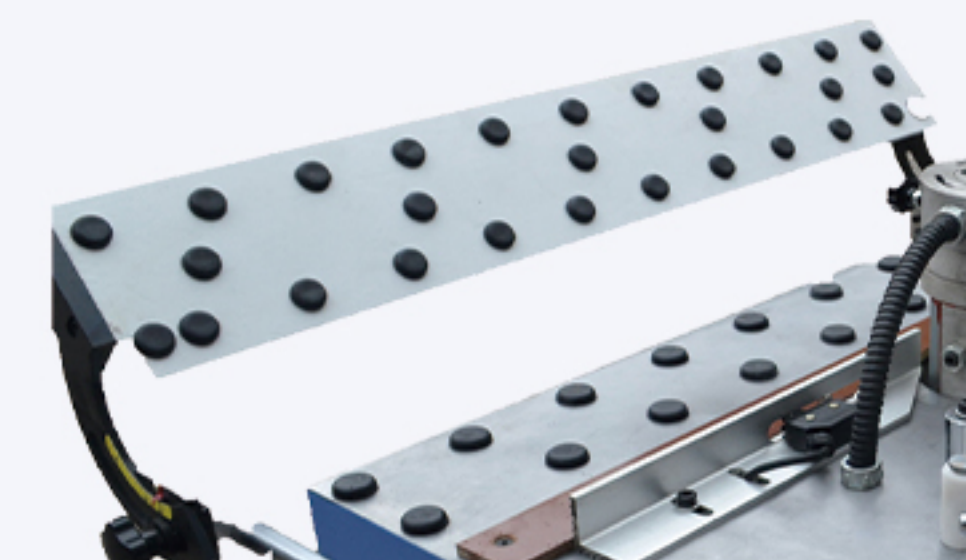

Working table with 45° tilt



Pneumatic cutting device

# MF515B / MF515C



Model	MF515A	MF515B	MF515C
Panel length	Min.150mm	Min.150mm	Min.150mm
Panel thickness	10-50mm	10-50mm	10-50mm
Edge thickness	0.4-3mm	0.4-3mm	0.4-3mm
Feeding speed	1-7m/min	1-7m/min	1-7m/min
Working pressure	0.4-0.5Mpa	0.4-0.5Mpa	0.4-0.5Mpa
Weight	192/230kg	168/200kg	175/210kg
Motor power	2kw	2kw	2kw
Overall size	1110*830*1000mm	950*750*1000mm	1000*830*1000mm
Packing size	1150*880*1110mm	1050*830*1110mm	1050*890*1110mm

# MF50J MINI



## PRODUCT HIGHLIGHTS



Touch screen control panel



Pre-milling unit with diamond cutters



Tefflon-coated glue tank can be replaced easily

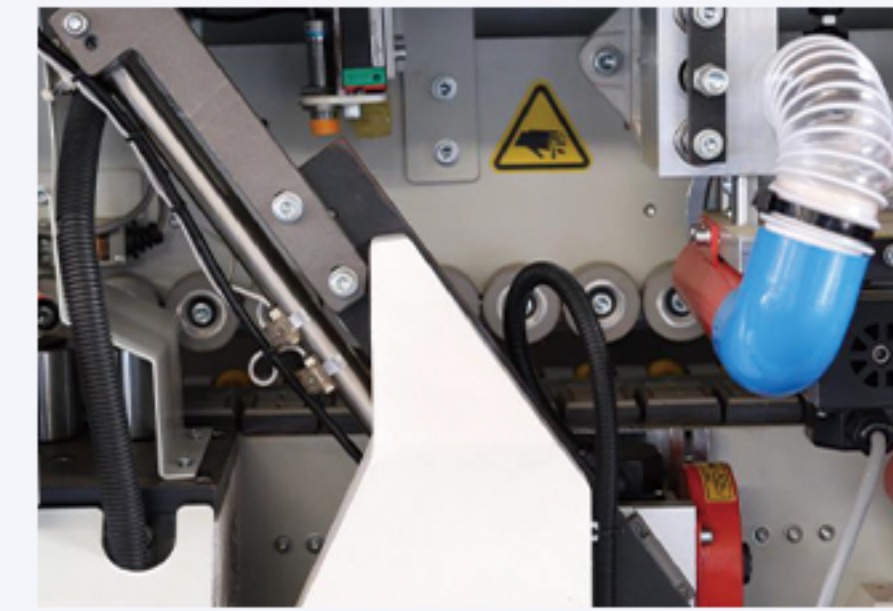

End cutting unit with high speed motor

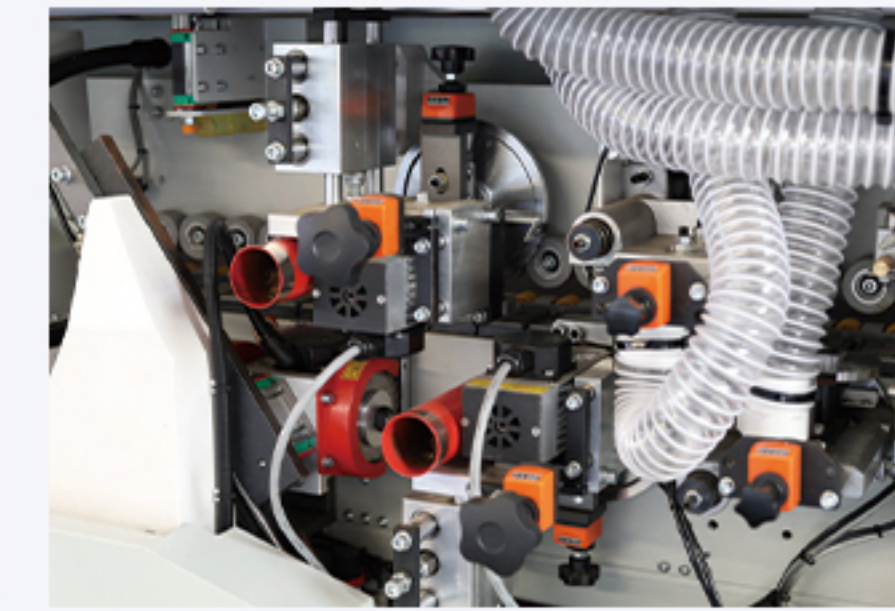

Fine trimming unit bring perfect finishing

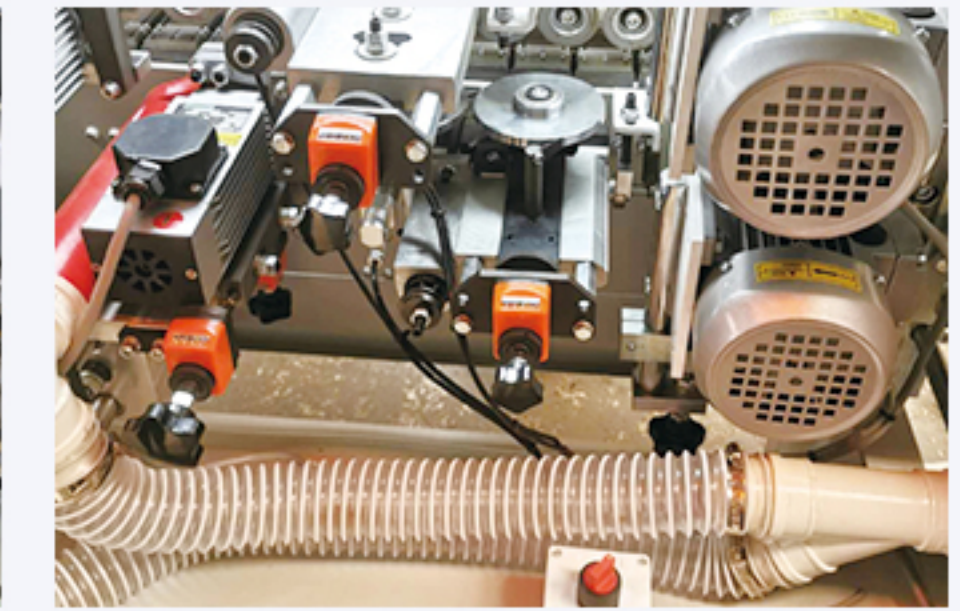

Scraping & buffing unit

# MF50Q



Pre-milling is optional



Model	MF50J MINI	MF50Q
Panel length	Min.70mm	Min.120mm
Panel width	Min.80mm	Min.80mm
Panel thickness	12-43mm	10-50mm
Edge thickness	0.4-2mm	0.4-3mm
Feeding speed	7m/min	13m/min
Working pressure	0.6Mpa	0.6Mpa
Weight	710kg	700kg
Motor power	6.15kw	5.49kw
Overall size	2730*1080*1230mm	2930*1110*1500mm
Packing size	2422*645*1245mm	2470*760*1500mm

## MF50G

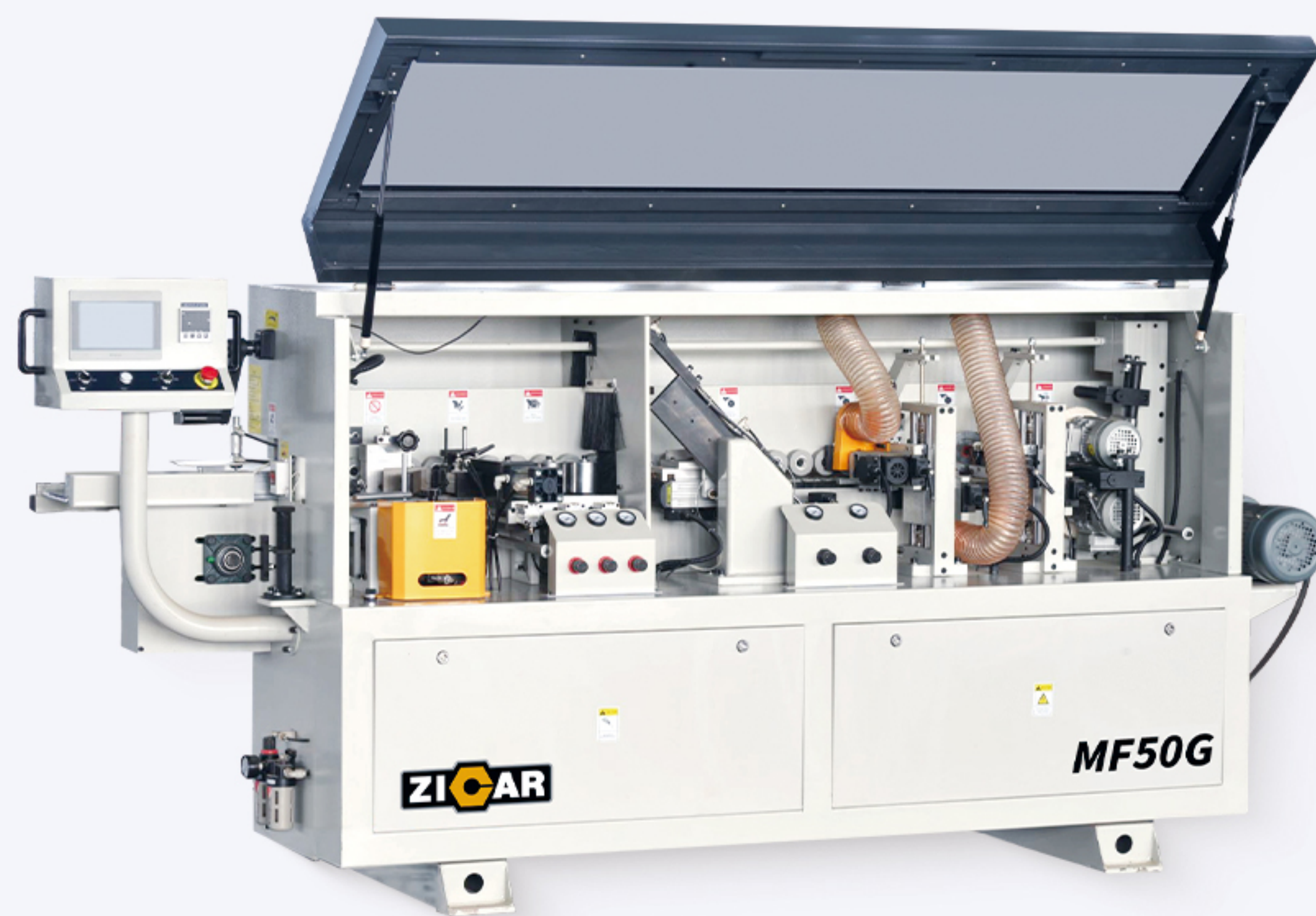

## PRODUCT HIGHLIGHTS



Feeding ruller

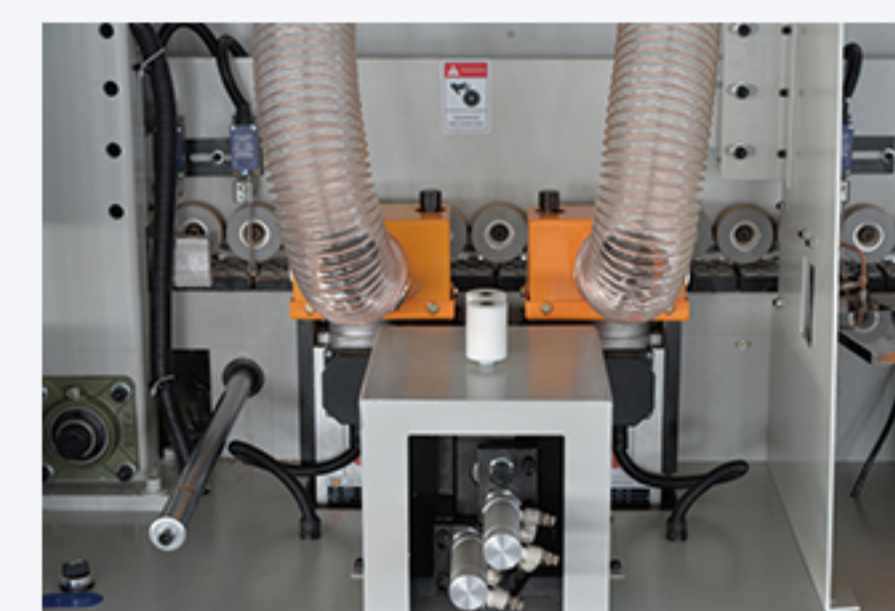

Pre-milling unit with diamond cutters



New design gluing system



End cutting unit with high speed motor



Trimming and buffing units



Powerful and stable conveyor motor

## MF50GM



Model	MF50G	MF50GM
Panel length	Min.140mm	Min.140mm
Panel width	Min 50mm	Min 50mm
Panel thickness	10-50mm	10-50mm
Edge thickness	0.4-3mm	0.4-3mm
Feeding speed	15 or 18m/min	15 or 18m/min
Working pressure	0.7Mpa	0.7Mpa
Weight	860kg	1150kg
Motor power	7kw	11kw
Overall size	3000*750*1360mm	3800*750*1360mm
Packing size	3100*890*1580mm	3850*900*1640mm

## MF450SG

Widely used for pull-free drawer panels, door panels, office counter tops, bathroom industry PVC, etc.

Can achieve the effect of beveled edge banding

Excellent performance for large industries

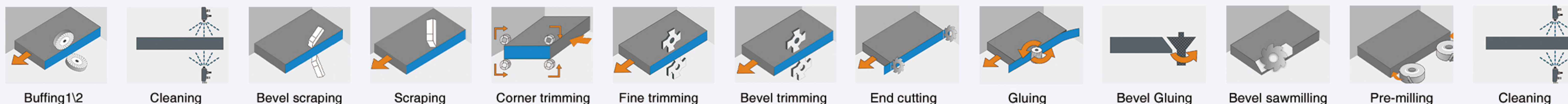
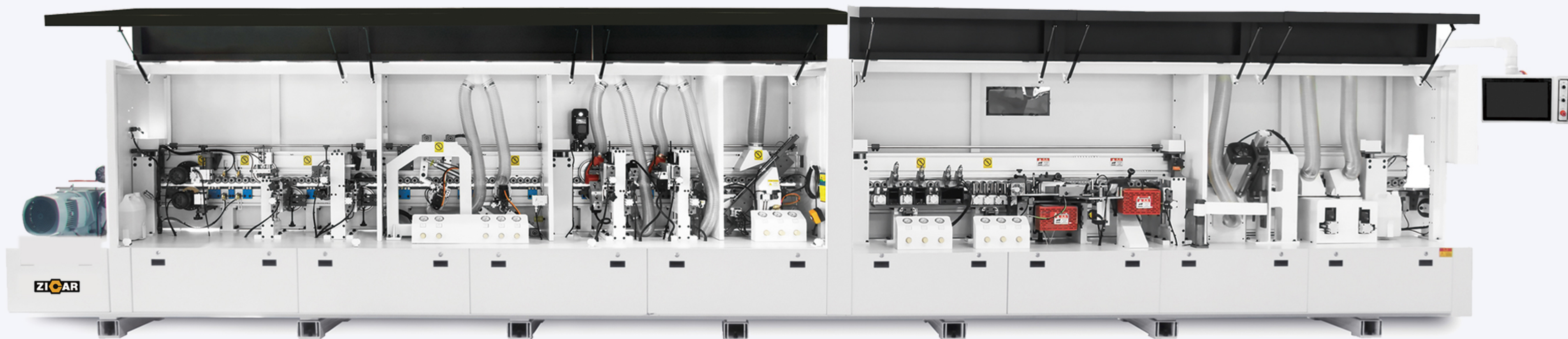

Model	MF450SG
Panel length	Min.120mm
Panel width	Min. 80mm
Panel thickness	Bevel: 16-40/25mm Straight: 10-60mm
Edge thickness	0.4-3mm

Model	MF450SG
Working pressure	0.6Mpa
Net weight	3500kg
Motor power	29.72kw
Overall size	10200*970*1800mm
Packing size	11000*1000*1800mm

## MF50FSKL

Automatic edge bander with regular glue pot plus quick-melt upper glue pot.

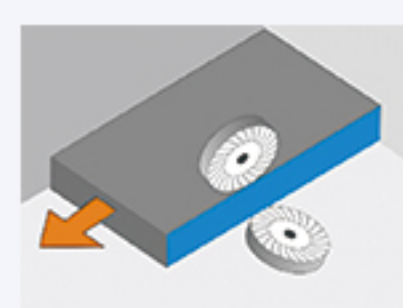

Buffing 2

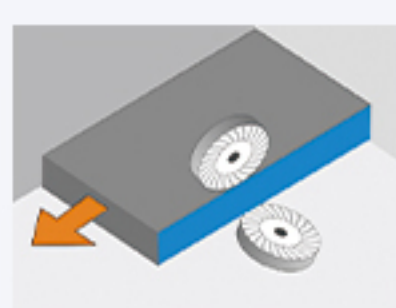

Buffing 1

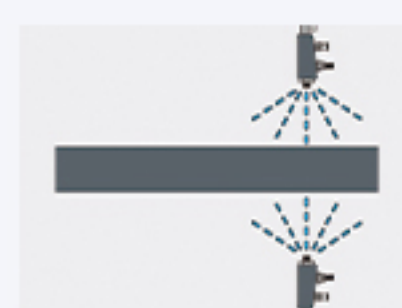

Cleaning

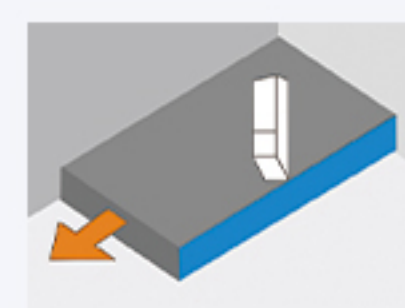

Flat scraping

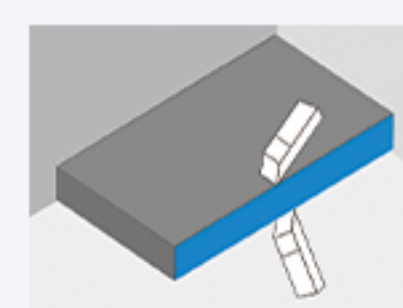

R scraping

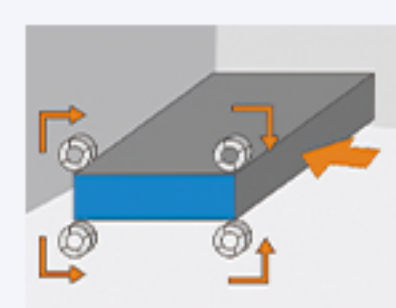
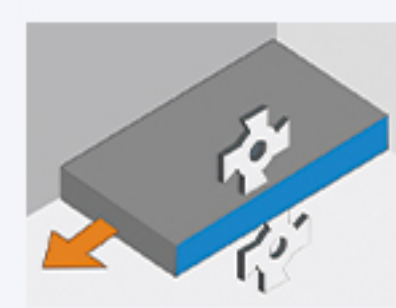
Corner  
trimming

Fine trimming



Rough trimming

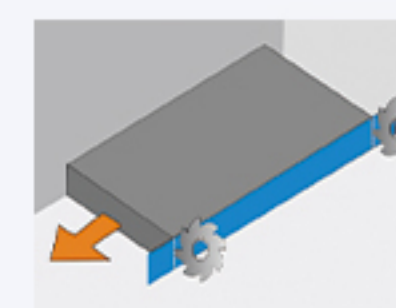

End cutting

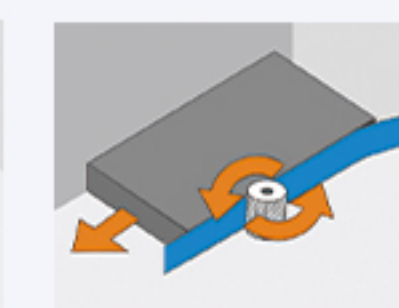

Gluing 2

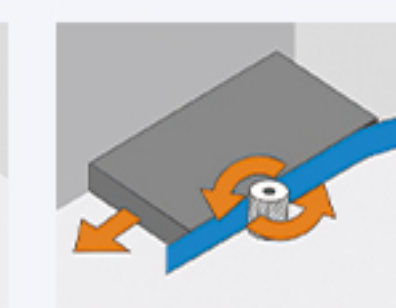

Gluing 1

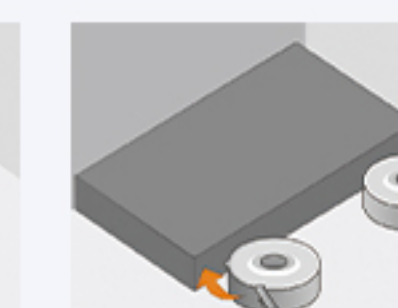

Pre-milling



Cleaning



Feeding Direction

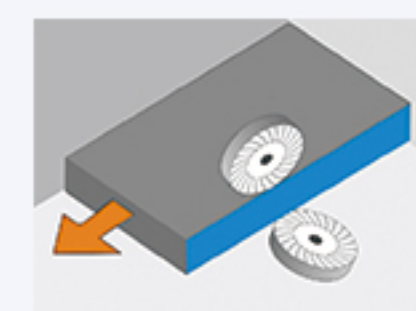

Buffing

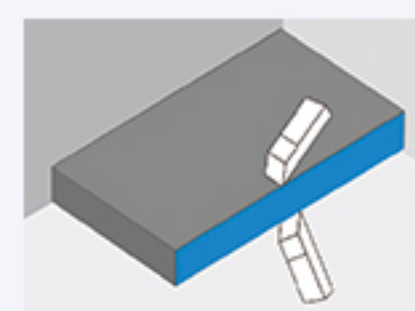

R scraping

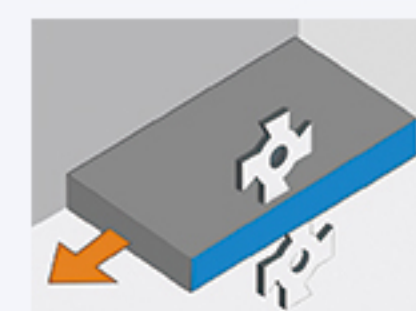

Fine trimming

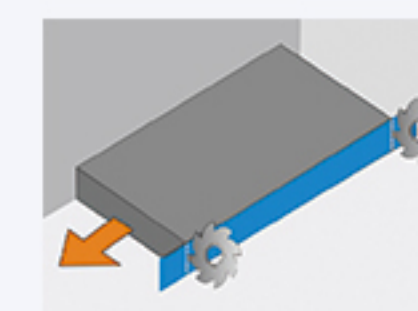

End cutting

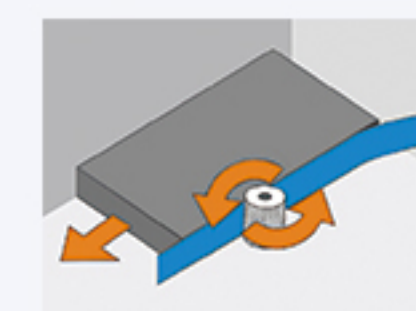

Gluing



MF50B

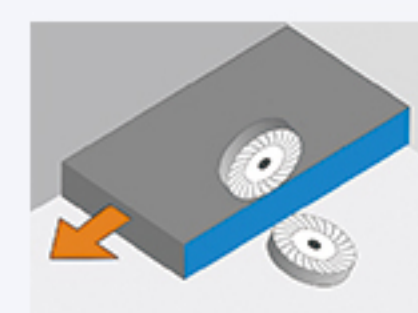

Buffing

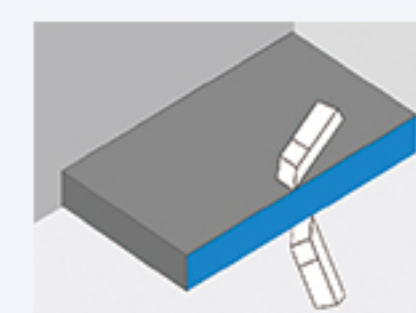

R scraping

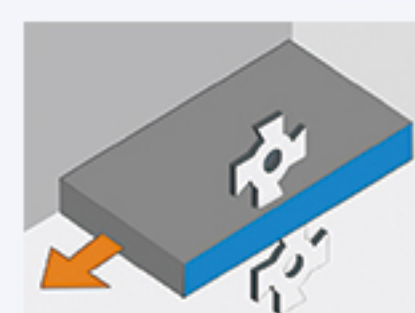

Fine trimming

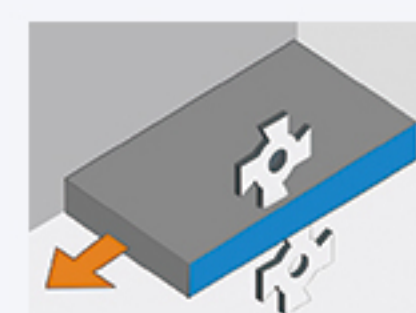

Rough trimming

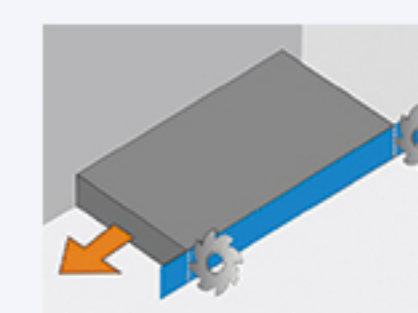

End cutting

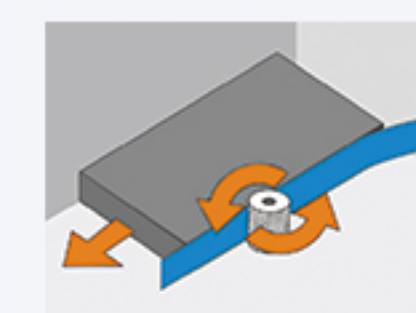

Gluing



MF50C

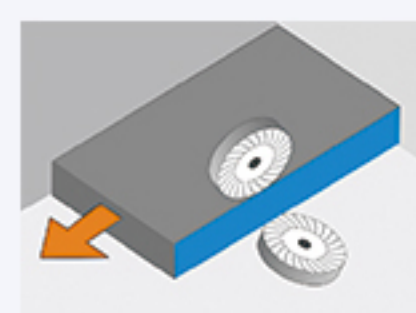

Buffing

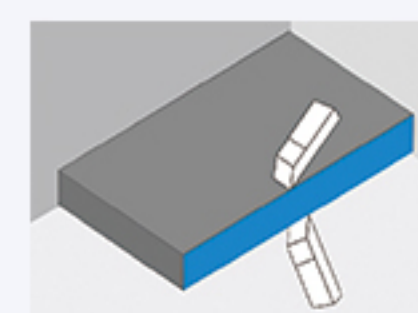

R scraping

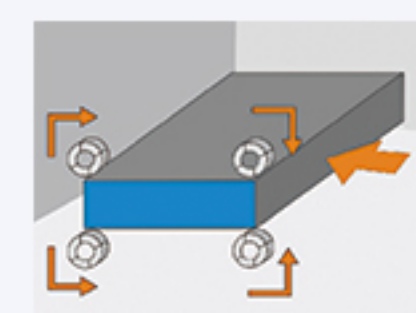

Corner trimming



Fine trimming

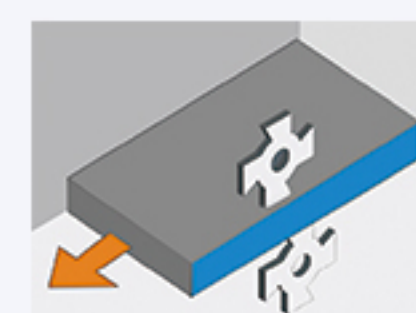

Rough trimming

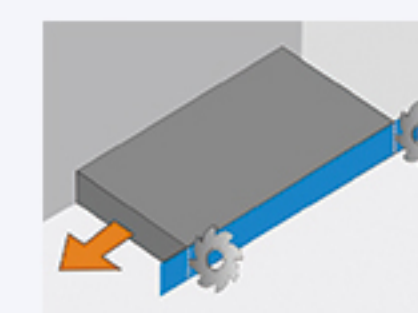

End cutting

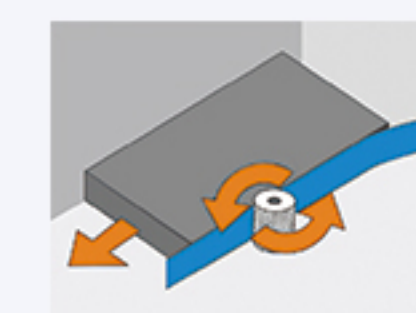

Gluing



MF50D

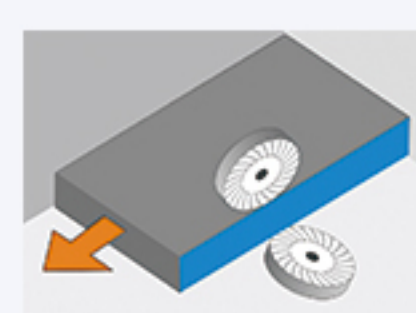

Buffing

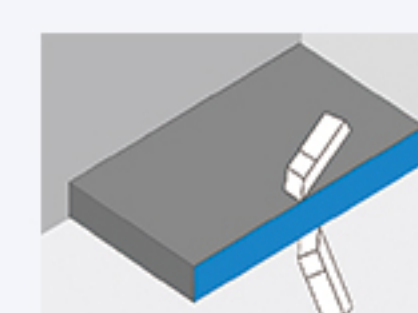

R scraping



Fine trimming



Rough trimming

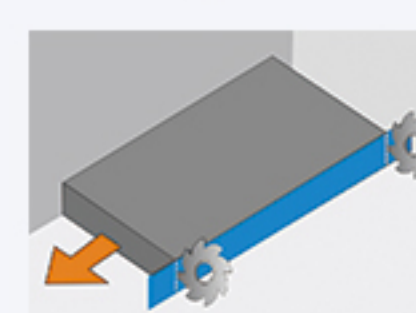

End cutting

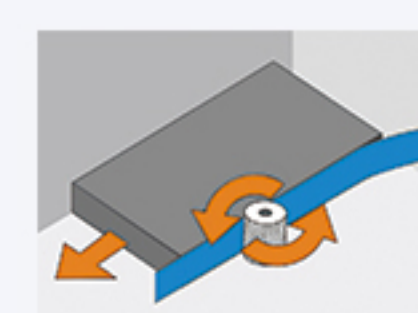

Gluing



Pre-milling



MF50E

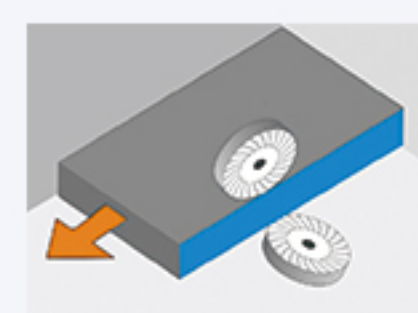

Buffing

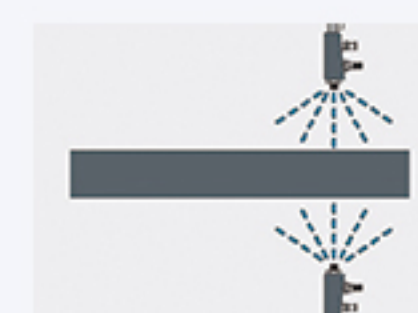

Cleaning

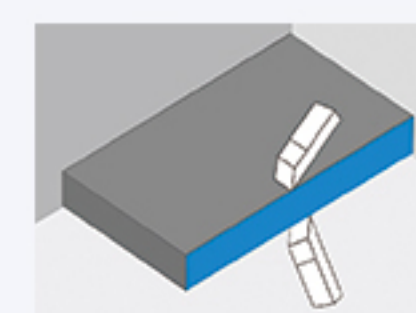

R scraping

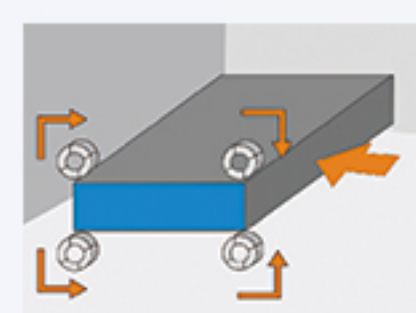

Corner trimming

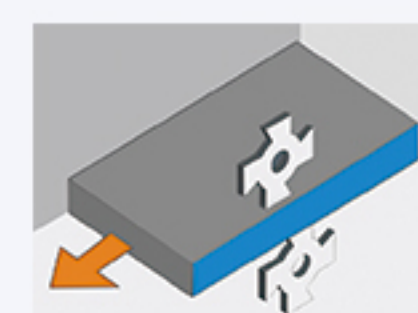

Fine trimming

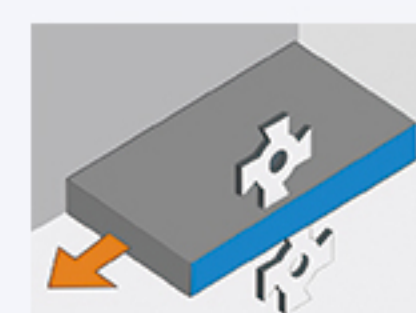

Rough trimming

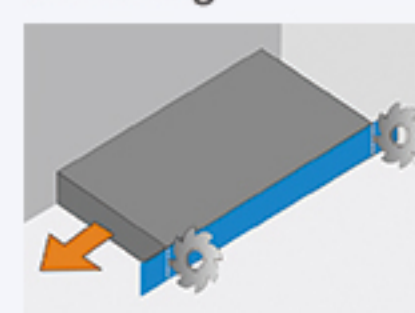

End cutting

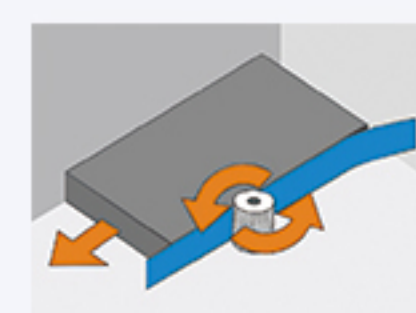

Gluing

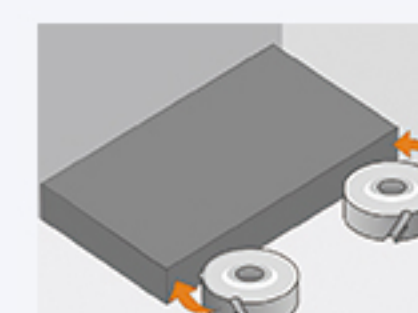

Pre-milling

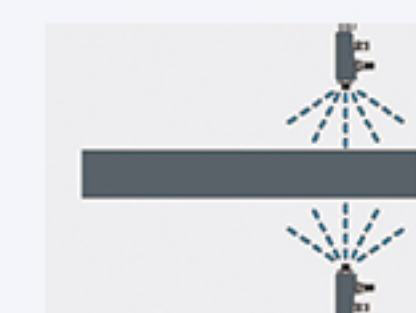

Cleaning



MF50F

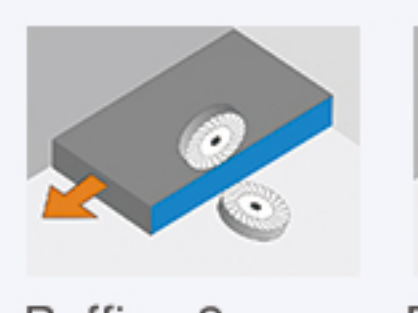

Buffing 2

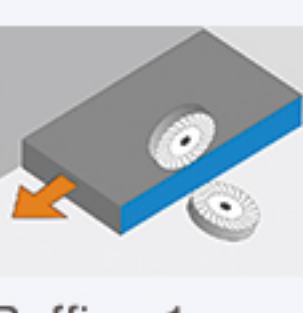

Buffing 1

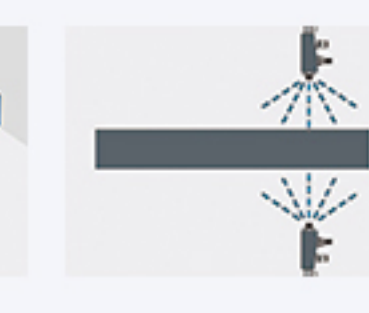

Cleaning



Flat scraping



R scraping

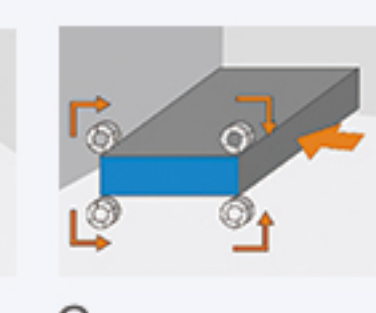

Corner trimming



Fine trimming



Rough trimming

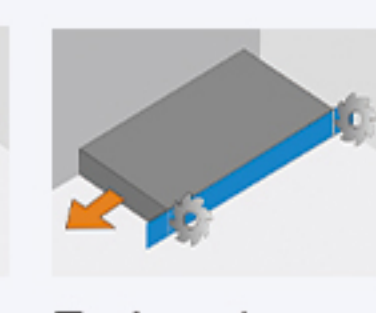

End cutting

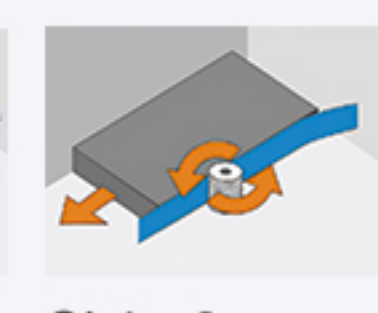

Gluing2

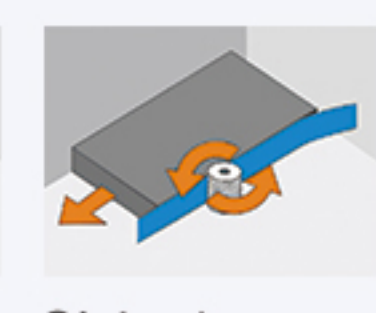

Gluing1

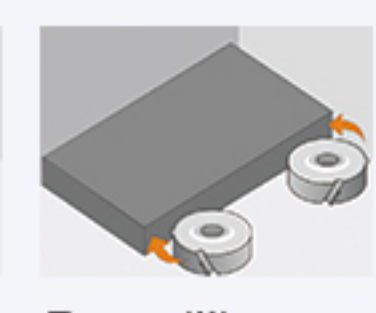

Pre-milling



Cleaning



MF50FSKL

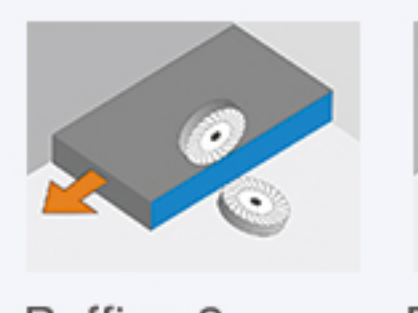

Buffing 2

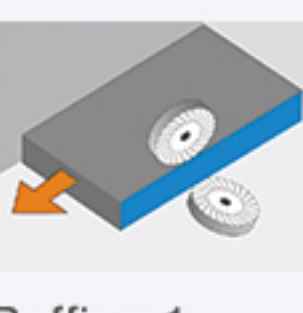

Buffing 1



Cleaning



Flat scraping

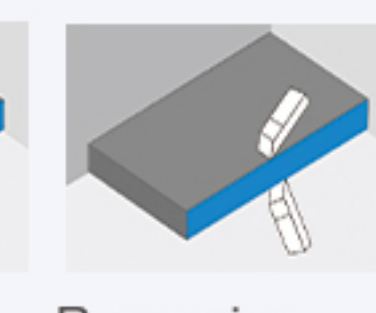

R scraping

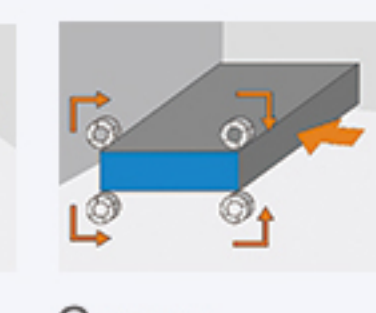

Corner trimming



Fine trimming



Rough trimming

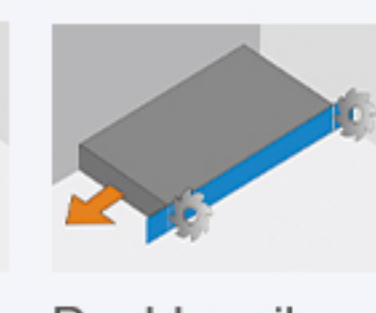

Double rails end cutting

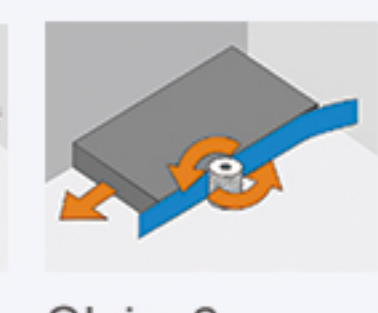

Gluing2

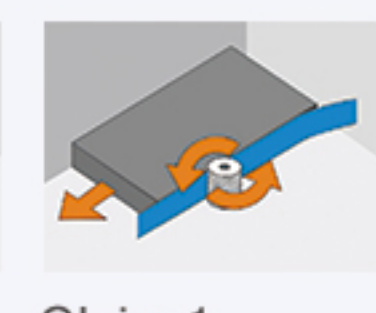

Gluing1



Pre-milling

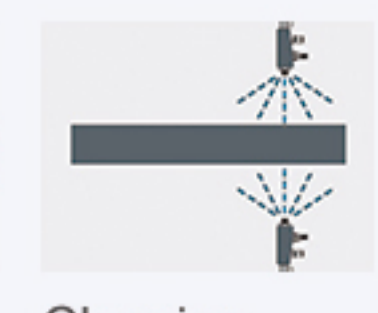

Cleaning



MF60FSQL

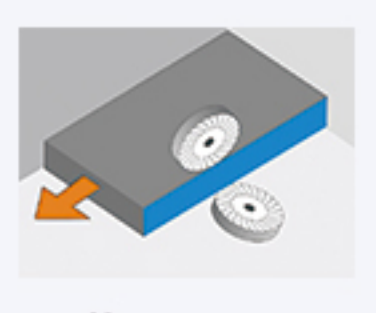

Buffing 2

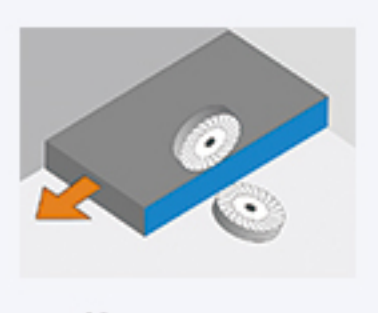

Buffing 1

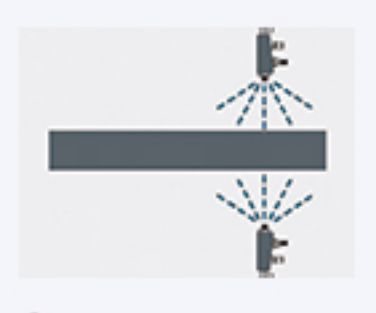

Cleaning

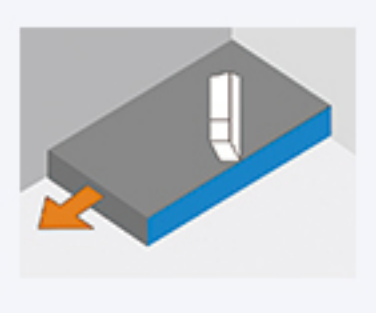

Flat scraping

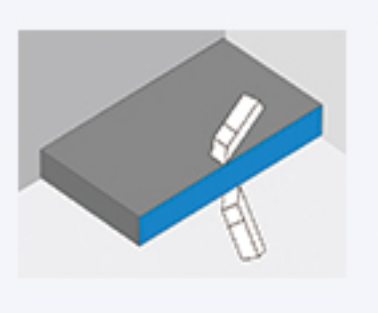

R scraping 2

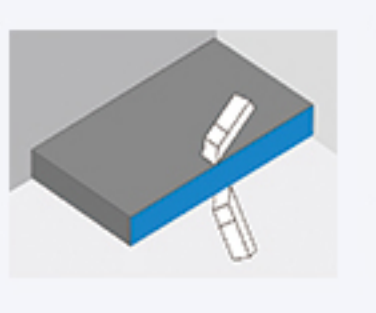

R scraping 1

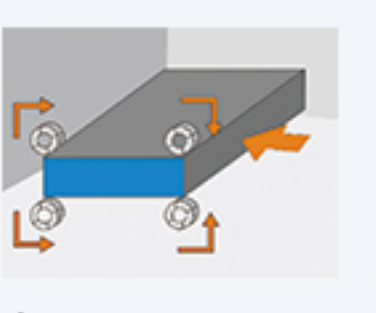

4 motors corner trimming

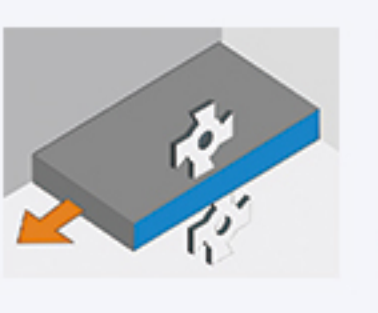

Fine trimming

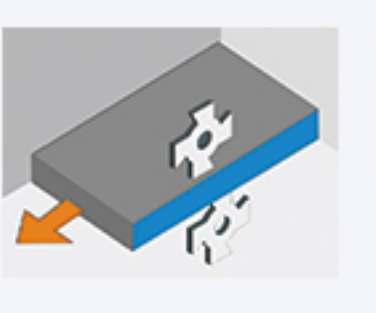

Rough trimming

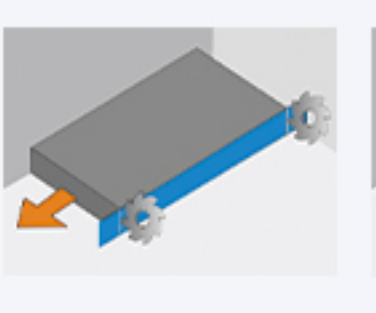

Double rails end cutting

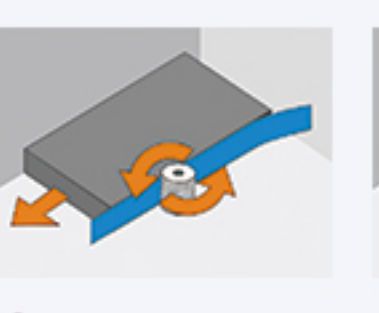

Gluing2

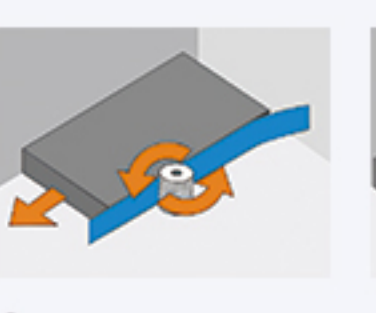

Gluing1

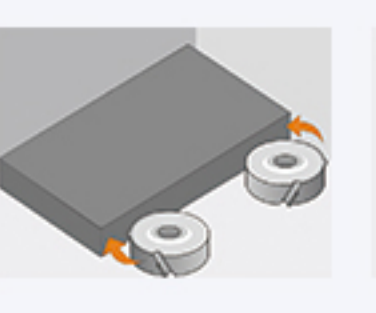

Pre-milling

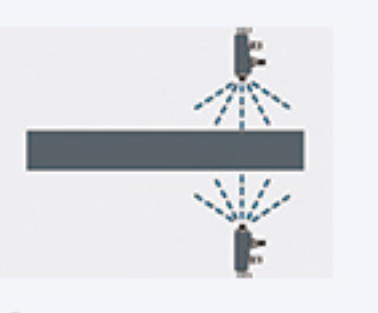

Cleaning



MF80FSQKL



Model	MF50B	MF50C	MF50D	MF50E
Panel length	Min. 120mm	Min. 120mm	Min. 120mm	Min. 120mm
Panel width	Min. 60mm	Min. 60mm	Min. 60mm	Min. 60mm
Panel thickness	10-60mm	10-60mm	10-60mm	10-60mm
Edge thickness	0.4-3mm	0.4-3mm	0.4-3mm	0.4-3mm
Feeding speed	15-23m/min	15-23m/min	15-23m/min	15-23m/min
Working pressure	0.6Mpa	0.6Mpa	0.6Mpa	0.6Mpa
Weight	1500kg	1650kg	2050kg	2200kg
Motor power	8kw	10kw	10kw	17.12kw
Overall size	4200*970*1800mm	4780*970*1800mm	5670*970*1800mm	5520*970*1800mm

Model	MF50F	MF50FSKL	MF60FSQL	MF80FSQKL
Panel length	Min.120mm	Min.120mm	Min.120mm	Min.120mm
Panel width	Min.60mm	Min.60mm	Min.60mm	Min.60mm
Panel thickness	10-60mm	10-60mm	10-60mm	10-60mm
Edge thickness	0.4-3mm	0.4-3mm	0.4-3mm	0.4-3mm
Feeding speed	15-23m/min	15-23m/min	15-23m/min	15-23m/min
Working pressure	0.6Mpa	0.6Mpa	0.6Mpa	0.6Mpa
Weight	2450kg	3500kg	3800kg	4200kg
Motor power	16.77kw	22.72kw	29.12kw	31.87kw
Overall size	6800*970*1800mm	8950*970*1800mm	10400*1050*1900mm	10500*1050*2000mm

## DUST COLLECTOR



FM9022



FM9030 / FM9040 / FM9055



FM9075

Model	FM9022	FM9030	FM9040	FM9055	FM9075
Motor power	2.2kw	3kw	4kw	5.5kw	7.5kw
Air volume	2350m³/hr	3150m³/hr	4450m³/hr	5500m³/hr	9000m³/hr
Suction holes diameter	Φ4"*3pcs	Φ4"*3pcs	Φ4"*4pcs	Φ4"*6pcs	Φ4"*6pcs
Bag diameter	480mm*2pcs	480mm*4pcs	630mm*4pcs	630mm*4pcs	650mm*8pcs
Weight	38/41kg	45/48kg	73/77kg	90/94kg	134/138kg
Packing size	970*560*530mm	1160*550*520mm	1470*690*690mm	1470*690*690mm	1460*1460*400mm 600*600*1400mm



Model	FM9011-24	FM9011-48
Motor power	7.5kw(11kw optional)	
Air volume	11000m³/hr	12000m³/hr
Suction holes diameter	Φ150mm*5pcs	
Bag diameter	Φ170*1800mm	Φ170*1800mm
Air speed	40-45m/s	42-47m/s
Weight	260/280kg	330/340kg
Packing size	2200*1000*800mm	2200*1000*800mm 1200*1000*800mm